



SAN FRANCISCO
Bicycle Guide

San Francisco Municipal Transportation Agency
311 • www.sfmta.com/bikes







Nathaniel P. Ford Sr.
Executive Director/CEO
San Francisco Municipal
Transportation Agency

“It’s an exciting trend that more and more people are choosing to bicycle in San Francisco for both transportation and recreation. Trips made by bicycle instead of by car have proven personal health benefits, and help all of San Francisco by reducing traffic congestion and air pollution. That’s why the SFMTA Bicycle Program continues to improve and expand facilities and training for bicyclists, freeing street space for transit, and making San Francisco a world-class bicycling city.”



San Francisco Municipal Transportation Agency

San Francisco Municipal Railway • San Francisco Department of Parking & Traffic



This guide was made possible by Proposition K Sales Tax funding, administered through the San Francisco County Transportation Authority. It is produced and distributed in collaboration with the San Francisco Bicycle Coalition and the San Francisco Bicycle Advisory Committee. Please direct questions or concerns about the Guide to the SFMTA Bicycle Program at 311, or send email to bicycle@sfmta.com.

Illustrations by Kevin Keck

Table of Contents

ABC Quick Bicycle Check	2
General Bicycle Rules	3
Where to Ride in Traffic Lanes: Intersections and Turns	6
Riding in Bike Lanes	10
Riding on Bike Routes	12
Bicycling at Night.....	14
Riding in Rain and Fog	15
Riding Near Streetcars, Trucks and Buses.....	17
San Francisco Bicycle Route Signs	19
Bicycles Allowed Use of Full Lane.....	20
Bicycle Parking in San Francisco.....	21
Bikes on Transit.....	25
Helmets	27
Avoiding Collisions and Injuries.....	29
Grates, Plates, Trenches and Potholes	32
What to do if you get in a Collision	34
The “CoExist” Public Outreach Campaign	35
Bicycle Safety Education.....	36
Waller Street Bicycle Learning Area	38
Parts of the Bicycle	41
Bicycle Sizing and Fit	42
Gearing and Shifting	43
Brochures and Publications.....	46
Important Telephone Numbers and Internet Links	back cover

“ABC Quick” Bike Check

Safe bicycling starts with a safe and well-maintained bicycle. These quick checks will take about a minute, and ensure that your bike is in safe working order:

A = AIR

Tires lose a little air each day on their own. Make sure your tires are inflated to the proper pressure, checking it every couple of weeks. If you can squeeze the tire, the air pressure is probably too low.

B = BRAKES

Spin the wheels and squeeze the brakes to make sure the pads are not worn and will stop the wheel from moving without applying much pressure. Have your brakes adjusted or replace the brake pads as soon as possible if either pad doesn't touch the rim.

C = CHAIN

Make sure your chain is not dried out or rusty, since it could cause sudden problems when riding. If it is worn, replace it. If the chain is dry, lubricate it by using a synthetic chain lubricant. If you find stiff links in your chain, you may be able to free them up by carefully and slightly bending the chain sideways back and forth until the stiff link loosens up. A new chain is relatively inexpensive and can do a lot to improve performance if your bike is shifting poorly. For a bike ridden regularly, a new chain



The quick release lever should be closed in the upright position, as shown above.

every year is good preventive maintenance.

QUICK = QUICK RELEASES

Check your wheel quick release skewers to make sure they're closed and tight. Improperly fastening quick release skewers can allow your wheels to shift and rub against the frame of your bike, or even fall off! In an urban environment, you may want to consider using locking skewers to further deter thieves from stealing your wheels off of your bike. "Slow release" skewers that require tools to remove can be purchased inexpensively or fashioned with simple hose clamps from the hardware store.

WEAR YOUR HELMET

Fit and adjust your helmet correctly so that it fits snug and the straps and slides are properly adjusted. See section on HELMETS for more info. Your helmet is not technically part of your bike, but think about it like a seatbelt: it must be put on and fastened properly before you start your trip.

General Bicycle Rules On The Street

GENERAL RULES ON THE STREETS -

A person riding a bicycle on the street or highway has all the rights and is subject to all the duties applicable to the driver of a vehicle, including DUI, obeying traffic signals, and all rules of the road. The California Vehicle Code (beginning with VC 21200), defines the rules and responsibilities of cyclists. You will find complete bicycle related vehicle codes at <http://www.dmv.ca.gov/pubs/vctop/vc/vctoc.htm>. Scroll down to Division 11, Chapter 1, Article 4: Operation of Bicycles



Bicyclists are required by California law to stop at STOP signs.

ENTER THE STREET IN A PREDICTABLE

WAY - Enter the street in a way that makes you visible to other users and yields right of way appropriately. Do not dart out into the street from a driveway, from the sidewalk, or from behind a parked car. Drivers are not

expecting to see you in this situation and may not have time to stop.

RIDE ON THE RIGHT SIDE - Because all vehicles operate on the right side, when drivers enter a road, change or cross lanes, by habit they look that way for possible conflicts, and often will not see someone coming from the wrong direction. Surprising motor vehicle drivers is never a good idea. Wrong-way riding is one of the leading causes of crashes, accounting for 15 to 20% of all collisions with cars. RIDING WITH TRAFFIC makes you more visible and predictable to other street users.



Cyclist behind the car, going the wrong way.

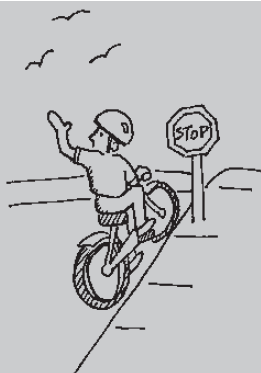

SIMPLY OBEYING THE LAWS AND FOLLOWING THE RULES OF THE ROAD WILL HELP YOU AVOID MANY COLLISIONS. RIDING DEFENSIVELY, BY BEING PREPARED FOR UNPREDICTABLE ACTIONS OF OTHERS, WILL ALSO HELP YOU AVOID COLLISIONS.

ADULTS DO NOT RIDE ON THE SIDEWALK.

Sidewalks are for pedestrians, not for bicycles. The San Francisco Transportation Code allows children under 13 prohibits adults from riding bicycles on the sidewalk:

ARTICLE 7: SECTION 7.2.12. BICYCLE RIDING RESTRICTED. SF Transportation Code restricts bicycle riding on sidewalks unless under the age of 13.

If the traffic on a street makes you uncomfortable riding on that street, choose an alternate route to your destination. Bikes should be walked on sidewalks, especially where there are pedestrians. Children under the age of 13 may ride on residential sidewalks in San Francisco, but must also yield to pedestrians. Parents should be careful to teach children to pay special attention to driveways.

COMMUNICATE!

Whether you communicate by using hand signals, your voice, a horn or bell, your position on the street, or even polite hand gestures, making yourself and your intentions known is always a good idea. Using hand signals is a great way to indicate your intentions to motorists, pedestrians and other cyclists. Hand signals are not always possible (in heavy traffic, on rough pavement, while crossing RR tracks, etc.) so it also pays to show others what you are doing by using correct positioning on the street. (See section on LANE POSITIONING AND INTERSECTIONS)

Use your voice or bell to let other cyclists know that you are passing – and always pass on the left side. Your voice, bell or horn, are also useful to alert drivers who are preparing to enter the street from cross streets, driveways, or parking lots. Sometimes these drivers are looking for gaps in motor vehicle traffic and fail to see

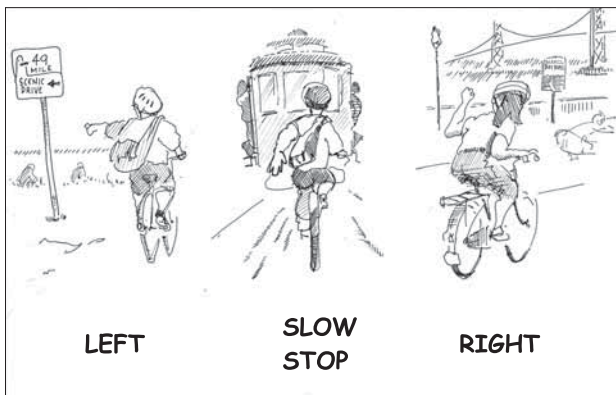

Get in the Habit of Signaling Your Intent

objects smaller than motor vehicles. Drivers preparing for left turns at intersections sometimes do not see cyclists. Getting a driver's attention in these cases is vital to your safety, but you should also plan to avoid a collision if the driver does not see you and pulls out in front of you. Slowing enough to be able to stop, or avoid the car with an INSTANT TURN, (see section on AVOIDING COLLISIONS) will prepare you to prevent a collision.

Many urban cyclists "filter through" traffic stopped at red lights. This is often done between the stopped traffic and the curb. This practice is actually illegal, as it is considered "passing on the right." There are many issues associated with filtering through stopped traffic, such as passengers getting out of cars, pedestrians walking through the stopped traffic, and very narrow spaces in which to maneuver. If you choose to filter through stopped traffic despite the obvious obstacles, you should do so with the utmost caution, and at significantly reduced speed.

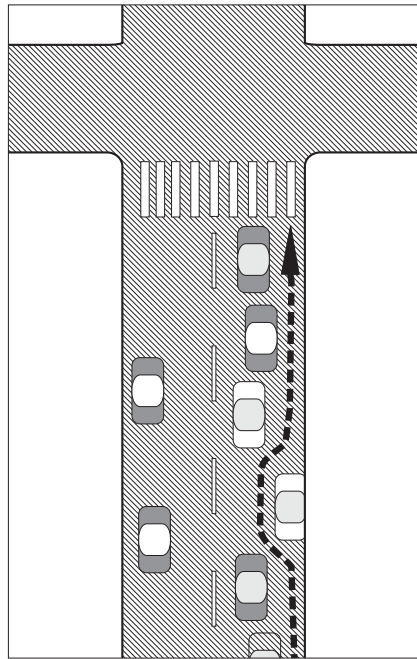

Filtering Through a Line of Waiting Cars.

Where to Ride in the Traffic Lane: Intersections and Turns

Where you ride on the street, or within the traffic lane, is vital to being visible, and allows others to predict where you are going and know what you are doing. Correct positioning on the street and appropriate paths of travel are great ways to be predictable, be visible, and communicate your intentions to other road users.

On streets where the lane is too narrow for motorists and cyclists to share side-by-side, and there is no shoulder or bike lane, **ride at least 3 feet from the edge of the roadway, or at least 4 feet from parked cars. Stay out of the “door zone!”** (The “door zone” is the area where car doors open and drivers get out.) This may mean that you will ride near the center of the lane in order to be visible and prevent motorists from passing you when there isn’t enough room. You may also take the lane when

you’re traveling at the same speed as traffic. Taking your rightful position in the lane keeps you out of motorist’s blind spots and reduces chances that oncoming traffic will not see you as they prepare to turn left across your path.

THE RULE OF THIRDS

Use your position on the street to show others where you are going. By being in the correct position on the street, you make yourself more visible to others and communicate what you are doing and where you are going. When you approach an intersection, there are three choices: a right turn, a straight path of travel, or a left/u-turn. You can communicate your choice by where you ride in the travel lane, or by which lane you choose on multi-lane streets.

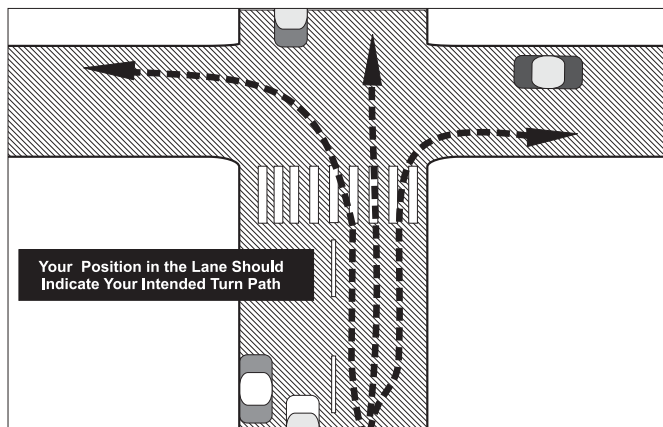

Rule of Thirds

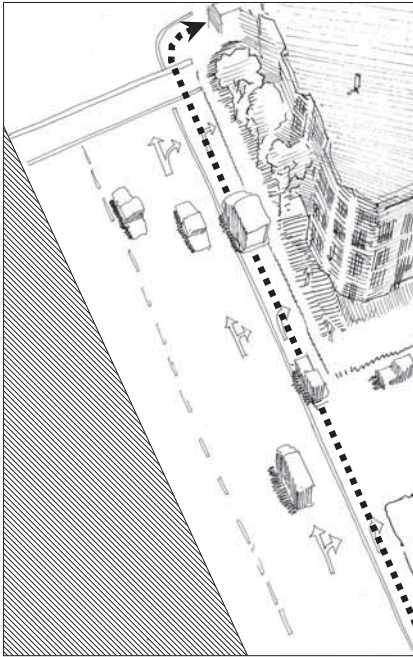

STRAIGHT THROUGH

A cyclist who is traveling straight should maintain a straight path of travel from one block to the next, staying out of the door zone of parked cars, and not wandering into the crosswalk (marked or not) or into empty parking lanes or spaces. A cyclist that fades right into the crosswalk while crossing straight through an intersection sends the false message that they are turning right, and vehicles may respond to this message by turning across the cyclist's path. When you leave the lane and ride in the parking lane, you have given up your right of way, and when you want to re-enter the traffic lane, you will legally have to yield to traffic before riding back into the travel lanes.

Right Turn From Double Turn Lanes

RIGHT TURNS

For a right turn, the cyclist should be in the right third of the lane, and should not leave space for vehicles to pass on the right.

LEFT TURNS

When making a left turn or U-turn at an intersection the cyclist should merge across the lane to a position in the left third of the lane, to show the intention to turn left. The

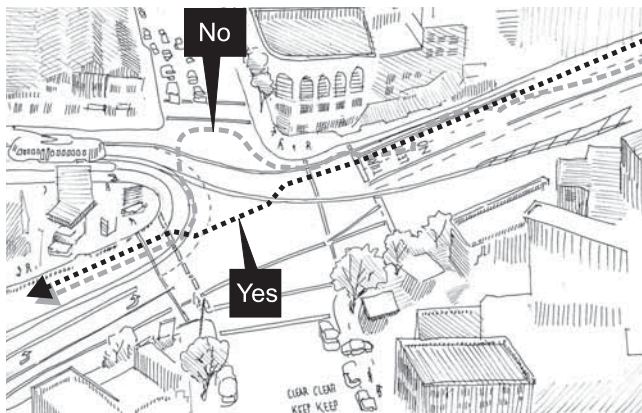

Straight through the intersection



Vehicular Left Turn, In Traffic.

rider above is making a “vehicular left turn” in the traffic lane.

“L” LEFT TURN (LIKE A PEDESTRIAN)

If you do not feel comfortable making a left turn in traffic, you may choose to go straight across, turn your bike to the left and cross straight again. This turn is called an “L” left turn because the rider’s movement across the intersection is shaped like a capital L. In some locations, like southbound Polk at Market, you will be instructed to make

an “L” left turn as seen in the sign below on Bicycle Route 25. Note: you should still stay out of the crosswalks as you cross. This type of turn is also called a “Box” left turn.

LEFT TURNS FROM MULTI-LANE STREETS

If you are making a left turn from a multi-lane street you should merge to the right side of a designated left turn only lane. If the left lane of a multi-lane street is used for both left turns and straight movements, you should take a position in the center of the lane to avoid having a car pull up next to you and proceed straight, preventing you from making your turn.

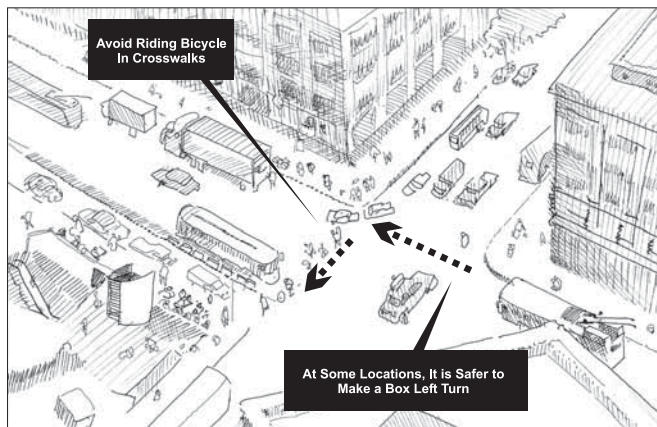

“L” Left (Box) Turn

LEFT TURNS USING MULTIPLE TURN LANES

When making a left turn on a street with multiple turn lanes you need to be in the lane that will put you in the desired position on the street after you make your turn. The right-most turn lane will typically be the lane that delivers a cyclist to the right lane of the destination street, where the cyclist can then proceed without a merge or without crossing paths with vehicles. If a cyclist chooses the left of two turn lanes, he or she will end up in a middle lane of the destination street, after the turn, and will likely have to merge back to the appropriate position on the right side of the right lane to continue straight on their trip.

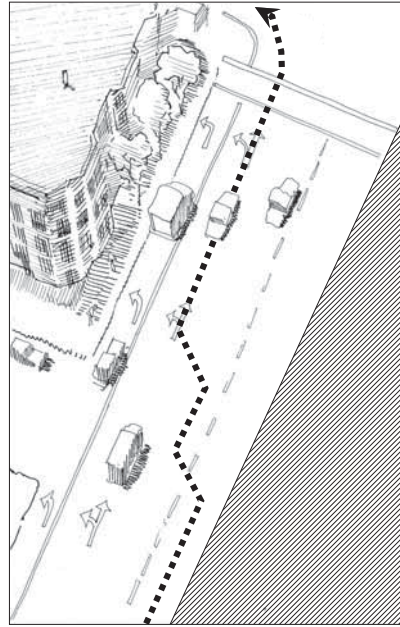

Left Turn on Multi-Lane Street

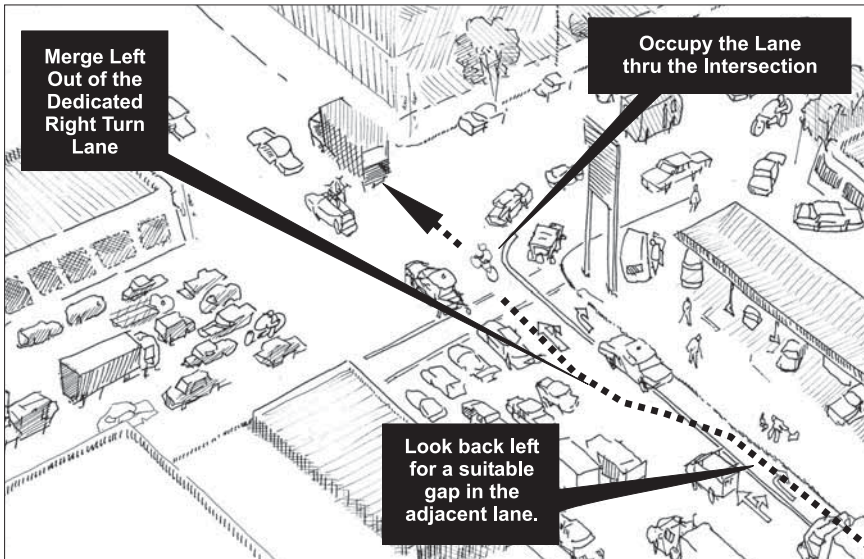

Straight Through Double Turn Lanes

Riding in Bike Lanes

Riding in bike lanes provides a certain amount of separation from the motor vehicle traffic, and gives cyclists an added sense of comfort while riding in urban areas. There are still rules that make riding safer in bike lanes.

RIDE IN THE RIGHT DIRECTION

Always ride the same direction as other traffic. It is extremely dangerous, and illegal, to ride the wrong way in a bike lane.

STAY OUT OF THE DOOR ZONE

Some bike lanes may be close enough to parked cars, or cars may park so that their door reaches into the bike lane. You need to stay out of reach of opening car doors.



This bicyclist is out of the door zone, safely in the bike lane.

DO NOT PASS ON THE RIGHT

Passing on the right is a dangerous practice and should always be avoided. Others do not expect it and it may cause dangerous conflicts.

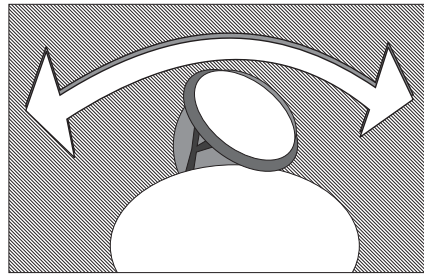

Pivot Your Head, Scan your Surroundings

ALWAYS SCAN FOR TRAFFIC AT INTERSECTIONS

Keep an eye out for turning vehicles at intersections. Drivers sometimes look for gaps in motor vehicle traffic, and only see cyclists once it is too late to stop, so you need to make sure that you see all of the intersection, all of the time.



This cyclist is riding straight through this Polk Street intersection.

RIDE A STRAIGHT LINE THROUGH INTERSECTIONS

When riding straight through intersections, do not fade to your right toward the curb and crosswalks as you approach intersections. These moves tell motorists that you are turning and they may anticipate a turn you do not make. Ride in a straight line from one bike lane to the one on the other side of the intersection.



A shoulder check allows you to see traffic behind you.

CHECK BEHIND YOU FOR TRAFFIC BEFORE LEAVING THE BIKE LANE

Before merging left into traffic to make a left turn, or even to go straight through an intersection when a bike lane is dropped at an intersection, you should check over your left shoulder behind you for traffic.



The BookMobile shares the dashed bike lane as it prepares to turn right.

MOTORISTS ARE ALLOWED TO MOVE INTO THE BIKE LANE 200 FEET IN ADVANCE OF MAKING A RIGHT TURN, and it is required for them to move right into the section of bike lane that is bordered by a dashed line (as shown in photo of the Bookmobile) as they prepare to make a right turn at an intersection. Cyclists should pass such motorists on the left, or wait behind them until they make their right turn.

Riding on Bike Routes



A cyclist shares the right lane on Market with cars

Class III Bicycle Routes (signed routes without striped bike lanes, but which may have sharrows) necessitate bicycling in or near the flow of motor vehicle traffic. Sometimes it means sharing the same lane space as motor vehicles. On these streets it is important for bicyclists to remember to stay out of the "Door Zone."

In order to better inform both drivers and cyclists how to more safely share these traffic lanes, the City of San Francisco

developed a new pavement marking. The SHARED LANE PAVEMENT MARKINGS or "SHARROWS" show where cyclists should ride on the street to avoid a suddenly-opened door of a parked car, and alert motorists to the presence of bicyclists in the traffic lane. They are also used in situations where it may not be obvious where cyclists should be riding, such as approaches to intersections with multiple turn lanes.

After several years of work, the SFMTA Bike Program won approval from the state of California to use this new pavement marking on

bicycle routes. More than 2,500 of these markings will eventually designate shared lane space on Class III bicycle routes throughout the city. On some streets,

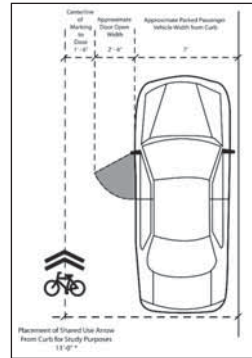

Sharrow and "Door Zone"

In Shared Lanes...

BIKES RIDE HERE



Find out more at
www.bicycle.sfgov.org

MTA Municipal
Transport
Authority



This ad ran on Muni buses during 2005 to introduce the new Shared Lane Markings

cyclists riding over the marking will take the entire lane. According to the California Vehicle Code (CVC) Section 21202, cyclists are to stay to the right of the roadway except under the following circumstances: to pass other cyclists or vehicles, to prepare to make a left turn, or when necessary to avoid conditions that make it unsafe to continue along the right. Riding a path to the left of the door zone, or other roadside obstacles, even if it means taking the entire lane, is permitted by the CVC.

If you see sharrows on the street, motorists have the right to be there, too. Shared lanes are different than bike lanes, which are set aside for cyclists and are marked by a solid white line and a different symbol. Cyclists are allowed on every street regardless of whether there is a marking or sign for them, unless specifically stated otherwise.



A cyclist rides safely past an open car door on Polk Street.



Sometimes sharrows are used to instruct cyclists which lane to use, such as this double right turn lane on Howard Street. Cyclists traveling straight need to ride in the center of the lane marked with Shared Lane Markings to avoid conflicts with turning vehicles.

Bicycling at Night



Reflectors and reflective clothing make you more visible.

VISIBILITY SHOULD BE YOUR FIRST CONCERN WHEN RIDING AT NIGHT.

Because you may not be as visible to others, and may not be able to see all the details as well either, riding a bit slower at

night is usually a good idea. Although many bikes are not fully equipped with reflectors and lights, you should know that state law requires you to have reflectors on the back, wheels and pedals of your bike, and a white front light that is visible from at least 200 feet, when riding at night. Many people use the blinking red LED (Light Emitting Diode) lights on the back of their bikes as well.

REFLECTIVE AND LIGHT COLORED CLOTHING are also very useful in making yourself visible to others at night. Wearing dark colors will make you blend into the darkness and make it much harder for motorists and pedestrians to see you.

POSITION ON THE STREET is an essential way in which you can help make yourself visible at night. At night you still want to ride where drivers expect you to ride. See sections on where to ride on the street for more detailed information.

Riding in Rain and Fog

Wet weather can be slippery on two wheels, but taking some easy precautions will limit your risks. The first and most important rule for wet pavement is: **SLOW DOWN!** Visibility is limited in rain and fog, so use lights and reflectors when possible. Fog can also make the street surface as wet as rainfall.

BRAKING AND STOPPING IN WET WEATHER: In wet weather your brakes take longer to engage, longer to stop your bike, and it is much easier to skid or slide your wheels as you brake. Start braking earlier, and use your brakes more gradually than you would on dry ground. The water makes a lubricating layer between the metal rim of the wheel and the rubber brake pad. In order to burn the water from your brake pads, you can also “pump” your brakes gently until they begin to work.



Townsend Street after a rain, with water on the tracks.

THE FIRST RAIN: OILY STREETS: Watch out when it's just rained for the first time in a long time. Streets get a coating of oil, tire rubber and other gunk that gets very slippery when you first add water. Be more careful and reduce your speed a bit on the first wet day or two of the season.

SLIPPERY WET PAINT AND METAL: Lane and crosswalk lines can be slippery when wet. Cornering too fast in wet conditions can lead to nasty falls. Utility covers, streetcars tracks, drain grates, BART/Muni grates, and construction plates that lack non-skid coating can also be very slippery. Try to avoid these things when the street is wet. If you have to ride on them, don't shift your weight or lean while riding on slippery surfaces.

PUDDLES: What lies under the puddle? Unless you know for sure, you may want

to ride around puddles to avoid potholes, cracks in the pavement or other things that lie hidden underwater. Even the debris that gathers in these low spots can be dangerous, or cause unwanted flat tires.



DRESSING FOR RAIN: For the novice and fair-weather cyclist riding in rain can be an obstacle, but you don't have to let wet weather keep you off your bike. Good cycling clothing is well-vented and allows the rider to regulate temperature while staying dry. Most California rain –and San Francisco fog- doesn't require a full rain suit, rain booties and a hood. Often, protecting yourself against the water sprayed up from the street is the main problem.



FENDERS are a great way to minimize the water and grime that comes up off the street onto you and your clothes. There are now many kinds of fenders, both permanent and "snap-on" that can be installed on almost any bicycle. A dedicated pair of "rain shoes" will allow you to get to your destination without ruining your favorite shoes.

Riding Near Streetcars, Buses, Trucks and other Large Vehicles

Riding safely near large vehicles on city streets requires special attention and caution.

TIPS FOR SAFE RIDING AROUND BUSES AND TRUCKS:

- Stay out of their “blind spots”
- Never pass on the right
- Do not try to squeeze through or ahead at bus zones – pass on the left
- Ride far enough behind so that the driver can see you in their mirrors
- Stay at least 4 feet from sides and wheels, so that you can’t fall under or into the wheels

STREETCARS AND RR TRACKS



Use Caution When Crossing Streetcar and RR Tracks.

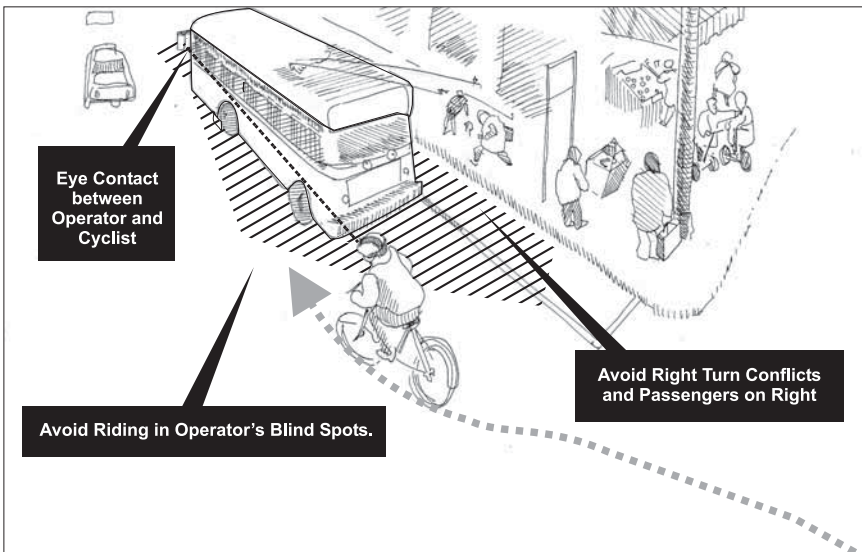

Passing a Bus or Large Truck

CROSS TRAIN TRACKS WITH CAUTION

When riding near streetcars and railroad tracks, pay special attention to the surface of the street. The weight of the trains may cause cracks or unevenness in the surrounding pavement as well. The tracks themselves can be slippery and awkward to cross – **try to cross tracks at 90 degree angles whenever possible**, as shown in the graphic above. It is easy to lose control as your wheel slides into a parallel track groove, and you will fall quickly and hard. Tracks also become more slippery when wet, so pay closer attention in foggy or rainy conditions. If you avoid the tracks on Market Street, you'll also avoid the BART/Muni ventilation grates (see section on GRATES, PLATES, TRENCHES AND POTHOLES).

AVOID CONFLICTS WITH TRANSIT

It is also important to remember that when

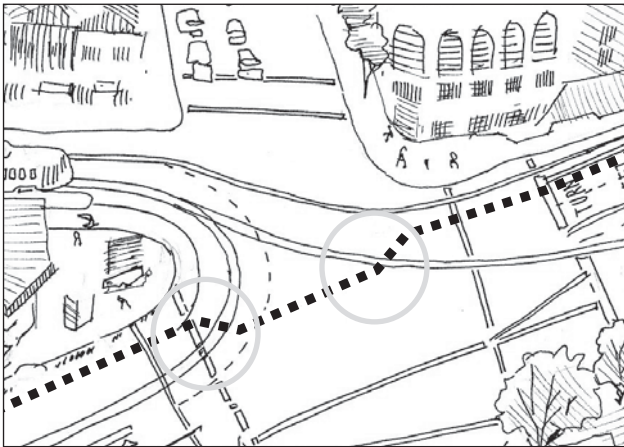

Try To Cross Tracks at a 90 Degree Angle



Muni tracks and grates on lower Market Street.

you obstruct or delay a train or bus you create a ripple effect, inconveniencing not only the people on that train or bus, but impacting the route service in general. Transit lanes may look and feel like beautifully wide bike lanes. They are not, and you are not LEGALLY allowed to ride in them. It is legally transit-only space, and if you choose to use that space, you need to do so without any negative impacts to transit.

Never challenge the streetcar! They are trains, weigh more than any vehicle on the streets, and require more time to stop.

Do not ride through streetcar tunnels or dedicated rights-of-way. These areas are designed only for streetcars and riding in or through them is dangerous and illegal.

San Francisco Bicycle Route Signs

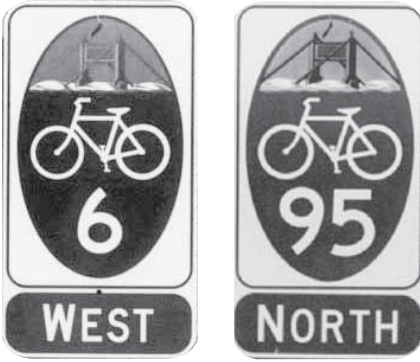

THE BICYCLE ROUTE NETWORK IN SAN FRANCISCO has a unique sign, and numbered routes that are based on the Federal Highway system. The signs, with Golden Gate Bridge, bicycle icon, and route number, are complemented by the destination placards at the bottom of the sign. East-west bicycle routes have even numbers increasing from north to south, with route 50, on Market Street, dividing the city. North-South bicycle routes have odd numbers, increasing from east to west. Three digit numbers denote connector routes. Cross-town routes are indicated by signs with a red bridge. Local route signs show a green bridge. Directional placards below some route signs direct the rider to popular destinations. To avoid confusion with local highways, bicycle route numbers do not duplicate highway numbers within San Francisco (1, 35, 80, 82, 101, 280).



Bicycles Allowed Use of Full Lane



WHAT THE SIGNS MEANS

When this yellow advisory sign is seen on a multi-lane street, it is meant as both an encouragement to cyclists to ride in the center of the lane, if necessary, and a notice to motorists that cyclists may be in the middle of the lane and that motorists should change lanes to pass the bicyclist.

WHERE THESE SIGNS ARE INSTALLED

The intention of the "BICYCLES ALLOWED USE of FULL LANE" sign is to reduce unsafe

behaviors by both motorists and cyclists, reduce related traffic injuries, and to encourage both cyclists and motorists to take the safest path where the right lane is narrow and must be shared. The sign has been installed on specific multi-lane streets with significant bicycle collision history.

WHEN MAY BICYCLES USE THE FULL LANE OR "TAKE THE LANE?"

On multi-lane streets, where there are no bike lanes, shoulder, or Shared Lane Markings, and the right lane is too narrow for motorists and cyclists to share side-by-side, bicyclists should ride at least 3 feet from the edge of the roadway or 4 feet from parked cars. You may need to ride in the center of the lane in order to be visible and prevent motorists from passing you when there isn't enough room. You may also take the lane when you're traveling at the same speed as traffic, which keeps you out of the motorists' blind spots and reduces conflicts with oncoming traffic.

Bicycle Parking in San Francisco



On-Street Bicycle Parking at the Main Library.

THEFT PREVENTION

Bicycle theft is common in San Francisco. You must lock your bicycle whenever and wherever you leave it, even if it is only for a few seconds. Nothing will stop a determined thief, but locking your bicycle correctly with the right equipment, will discourage the thief looking for easy targets.

USE THE RIGHT HARDWARE: If possible, combine two of these locking mechanisms when parking your bicycle:

U-LOCKS: Purchase a lock made with strong components (like hardened steel).



The very small size is useful for locking just a frame or wheel to a rack or pole, in combination with a cable to protect wheels. Larger sized locks allow cyclists to lock a wheel and frame to a rack or will fit around larger diameter objects.

CHAINS: Hardened, oversize chains such as the “New York Lock” are very strong and secure; however, they are very heavy, so you will have to weigh relative security vs. how much weight you want to carry. Other, smaller chains may be helpful in augmenting a u-lock, but can be cut easily, so ask questions of the retailer where you are buying the chain. You will also need some kind of lock to secure the chain around your bike.

CABLES: This can be as a second security measure, since they are lighter and more easily carried but shouldn’t be used alone! Use a braided cable at least 3/8” thick. Again, you will also need a lock.



Both wheels and the bicycle frame should be locked to the rack.

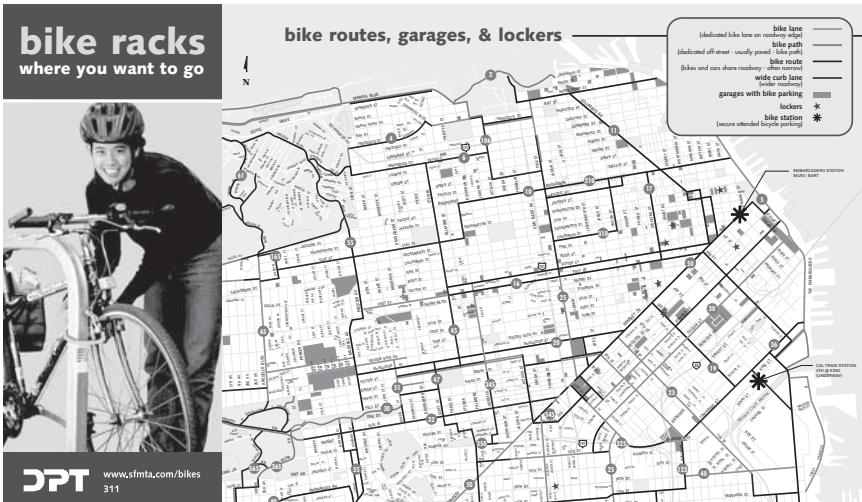

This brochure and map provide complete bike parking information for San Francisco. To request a bicycle locker, a bicycle rack, or this brochure, call 311.

HOW TO LOCK YOUR BIKE

LOCK THE ENTIRE BIKE: Make sure you lock both the wheels and frame. This might mean you'll need to remove your front wheel (if it has a quick-release hub) and lock it.

If you lock just your wheel, a thief could steal the rest of your bike – or vice-versa. Leave as little slack in your chain or cable as possible, and make sure that there is little or no space in the middle of the lock that would allow a thief to pry the lock open.

WHERE TO LOCK YOUR BIKE

If you are planning to leave your bike all day at your place of work, you may want to consider finding bicycle parking inside a building or renting a bicycle locker.

Habitual bike parking at a certain place and time alerts a thief to a possible theft opportunity.

VISIBILITY: where possible, lock bicycles within sight of where you're going. Don't be the only bicycle parked in an area – it is safer to park where there is activity.

BICYCLE RACKS: The SFMTA Bicycle Program has installed thousands of bicycle racks throughout San Francisco. Many are concentrated on bicycle corridors, so there is a good chance there will be a rack where you want to go. Ideally, racks are meant to provide short-term parking, so they are best used for recreation or shopping trips. If you find there is no rack where you intend to park, please contact the SFMTA Bicycle Program at 311 or e-mail bicycles@sfmta.com to request a rack.



ON-STREET BICYCLE PARKING: Where bicycle parking demand is high and fronting businesses are amenable, the SFMTA will consider installing on-street bicycle “corrals”: groups of bike racks situated in the parking lane. The first such installation in San Francisco was in front of the Grove Street entrance of the Main Library. This project has been very successful in eliminating sidewalk encroachments and expanding bicycle parking spaces at the same time.

SECURE BICYCLE PARKING - If you plan to park your bike at your workplace or residence, you may want more secure parking - that is, parking your bike in a garage which has bicycle racks and an attendant, or renting a bicycle locker from the MTA Bicycle Program. Garage locations with bicycle racks can be found on our website, www.sfmta.com/bikes, or on the “San Francisco Bike Map”, available for purchase at many bike shops, book stores and Rainbow Grocery at 13th and Folsom Streets.

BIKESTATIONS are a relatively new alternative for secure bicycle parking. They

are located at transit hubs in San Francisco and provide free, attended parking and long hours. There are bikestations at the Embarcadero Bart Station and at the Caltrain Station at 4th and King Streets. There are also bicycle racks inside the paid entrance of the 16th Street and Civic Center Bart Stations. Although 16th Street and Civic Center parking are not directly attended, they are more secure than parking your bicycle on the streets.

WHERE THERE IS NO BIKE RACK: PARKING METERS – If you lock your bicycle to a parking meter, make sure to use a u-lock, since thieves can just slip a bike locked with a chain or cable over the top of the meter. Be aware that bikes locked to meters often twist and fall, creating an obstacle for pedestrians.

SIGN POLES – These are not the best place to lock your bike, since often a sign at the top of the pole is not enough to stop a thief from lifting your bike over the top, as with a parking meter. Also, check whether the pole has a secure footing before you lock to it – it may be easily pulled out of the ground.

TREES – Do not lock a bicycle to a tree – it damages the tree trunk and roots.

SAN FRANCISCO CITY ORDINANCES REQUIRING BICYCLE PARKING

Information regarding which garages and buildings are required to install bicycle parking can be found on our website, www.sfmta.com/bikes.

A summary of the San Francisco bicycle parking ordinances is as follows:

155.1 – requires bicycle parking in City-owned and leased buildings

155.2 – requires bicycle parking in certain privately-owned and all City-owned automobile garages

155.3 – requires shower and locker facilities in certain new or renovated buildings

155.4 – requires bicycle parking in certain new or renovated buildings

155.5 – requires bicycle parking for residential uses

If you find a garage or building out of compliance, the Planning Department should be notified.

BICYCLE REGISTRATION AND RECOVERY

REGISTERING YOUR BIKE – When you obtain a new bike, write down the serial number, take a photo, and put them in a safe place. You might also register your bike at the National Bike Registry, a good on-line resource at www.nationalbikeregistry.com.

It is important to have the serial number so that you can prove the bike that was stolen and recovered is yours. In addition, it helps the police identify and locate the proper owner.

WHAT TO DO IF YOUR BIKE IS STOLEN

Report the theft to the police. Call 415/553-0123 - then request a printed version of the report at 415/553-1289. Provide clearly detailed descriptive information and the bicycle’s serial number. The San Francisco Police Department is linked to the national database of stolen property, so you can call the SFPD at any time to ask if a bike with your serial number has been returned anywhere in the U.S.

Bikes on Transit

SF MUNI

All Muni buses have bike racks that hold two bikes on a first-come, first-served basis. Bicyclists should remove packs and other detachable items from the bicycle before loading, and should not hang helmets and other objects from the bicycle. To see a short instructional video on loading bikes on Muni bus racks, go to www.sfmta.com/bikes. You may want to lock your bike before placing it on the rack, and/or sit in the front of the bus where you can see your bicycle to deter bike theft. Alert the driver when you are getting off, so that the bus doesn't leave the stop before you have off-loaded your bicycle. Bicycles are NOT allowed on Muni Metro trains, cable cars, or on the F- Market historic streetcar line. As of spring 2010, folding bikes are not allowed inside any Muni vehicles, but the SFMTA is re-examining this policy. Like standard bikes, folding bikes may be placed unfolded on bus racks, on a first-come, first-served basis. Before lifting your bicycle in place, shift the chain to the big cog of the rear wheel so that the rack does not interfere with your derailleur. Don't forget your bike on the bus! If this happens to you, call 311 immediately.

311

www.sfmta.com/bikes

BART

Bicycles are allowed on BART trains during all times except peak commute hours in the heavy commute direction. Bikes are not allowed in the Downtown Oakland stations during peak commute hours at all. Folding bicycles are allowed on all BART trains; during peak commute hours they must be folded before entering the train. Many BART stations have bike lockers, some stations have bike parking inside the paid areas near station agent booths, and all stations have on-demand bicycle parking racks. For more information on exact trains that prohibit bicycles, see the BART schedule at www.bart.gov/bikes

510.465.2278

BART Bike Lockers 510.464.7133

CALTRAIN

Rail service between San Francisco and Santa Clara: the northern-most car (with bike decal on the door) carries 24 or 32 bicycles. 34 weekday trains now have two-bicycle cars, doubling the capacity of bicycles that can be accommodated. Bicycles should be clearly tagged with destination and stacked in order of exit station. Folding bicycles are allowed on all cars. Bike lockers are available at 27 stations.

800.660.4287

www.caltrain.com

SAMTRANS

Bus service between San Mateo and San Francisco Counties. Buses are equipped with bike racks that hold two bicycles, and bicycles are allowed inside coaches with less than 50% passenger occupancy. Folding bicycles are permitted on-board.

800.660.4287

www.samtrans.org

AC TRANSIT

Many buses are equipped with bike racks that hold two bikes, including Transbay lines N and O. Cyclists must load and unload their own bicycles. Folding bicycles are permitted on-board.

Call 511

www.511.org

GOLDEN GATE TRANSIT

Buses: All GGT buses are equipped with racks that hold two bicycles. Folding bicycles are permitted on-board.

Ferries: Bicycles are welcome aboard all Larkspur and Sausalito Ferries on a first-come-first served basis up to 25 bicycles. The new Larkspur Catamaran allows 15 bicycles.

Call 511

www.511.org

AMTRAK

Bicycles are allowed on all four roundtrip Capitol Corridor trains and on connecting buses. Bikes are permitted on two of the four round trip San Joaquin trains and the

connecting buses. Scheduled departures leave from SF Ferry Building via bus connection.

800.USA-RAIL

www.amtrak.com

CALTRANS BAY BRIDGE BIKE SHUTTLE

Runs from 6:20 A.M. to 8:30 A.M. and 3:50 P.M. to 6:15 P.M. in both directions on the bridge. Check website for exact schedule.

510.286.0589

<http://www.dot.ca.gov/dist4/shuttle.htm>

BLUE AND GOLD FERRIES

(VALLEJO BAYLINK AND ALAMEDA-OAKLAND FERRIES)

Ferries from San Francisco to Tiburon, Vallejo, Alameda and Oakland. Bicycles are allowed at the Captain's discretion, on first-come, first served basis.

Blue and Gold 415.773.1188

www.blueandgoldfleet.com

Vallejo Baylink 707.643.3779

www.baylinkferry.com

Alameda/Oakland 510.522-3300

www.eastbayferry.com

ALAMEDA HARBOR BAY MARITIME FERRY

Provides service from Alameda to San Francisco. Special service to 49er and Giants games. Bicycles allowed at Captain's discretion.

510.769.5500

(Serving AT&T and Candlestick Parks)

Helmets

SHOULD YOU WEAR A HELMET?

Yes! California law requires bicyclists under 18 years of age to properly wear an approved bicycle helmet whenever riding on public roads and parks. A helmet can save you from preventable and unnecessary head and brain injury. Standard bicycle helmets are still the most commonly used. New “commuter” helmets have been developed with less of a sporty look, but may offer more head coverage and feature a tougher shell that can better absorb the wear and tear of daily use. Regardless of cost or looks, all helmets that bear CPSC, Snell, or ANSI bicycle helmet certifications offer equal protection and will prevent head injuries when worn properly. Uncertified helmets made without expanded polystyrene will not protect your brain from trauma in a crash and should not be worn.

PROPER HELMET FIT AND USE

As shown below, helmets should be worn level on the head, with one finger’s width between the rider’s eyebrow and the bottom edge of the helmet. Ear slides should be positioned just below the ears

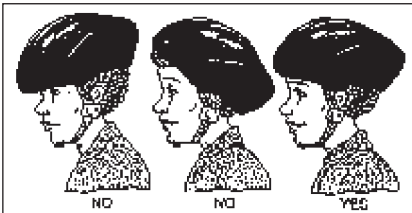

and chin straps should be snug, with no visible slack under the chin.

Bicycle helmets typically come in at least 3 different sizes.

Small is typically 20 to 22 inches;

Medium is typically 22 to 23 1/2 inches;

Large is typically 23 1/2 to 24 1/2 inches.

Infant, Toddler, Youth and XL sizes are often also available.

If your helmet does not fit correctly, it will not protect you. Similarly, if you do not adjust the straps, buckles and ear slides correctly, even a properly fitted helmet may not protect like it could and should—even ear slides are crucial to protecting your brain! Take a moment every couple of months to re-check and adjust your helmet.

The most important things to consider when buying a helmet are that it fits you correctly and that you like it and will want to wear it. Some helmets come with a removable visor, which is handy in sunny weather,

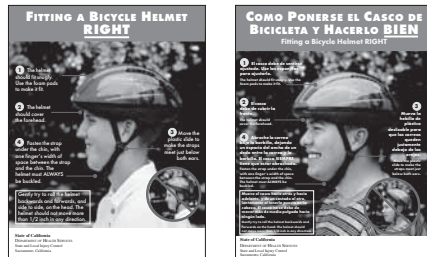

The bilingual helmet fitting guide above is designed for youth, but applies to all ages. It is available as a pdf at www.sfmta.com/bikes

but the helmet industry's annual review of injuries shows that in a crash, these visors can dislodge and cause facial lacerations.

More expensive helmets do not equate to safer helmets. The added benefits you get are lighter weight, advanced strapping systems, more vents, or more rugged construction. Be aware of gimmicks. You want a smoothly rounded outer shell, with no sharp ribs or snag points. A large number of vents may mean less area contacting your head, which could concentrate force on one point. "Aero" helmets are not noticeably faster, and in a crash the "tail" could snag or knock the helmet aside. Skinny straps are less comfortable. Dark helmets are harder for motorists to see. Rigid visors can snag or shatter in a fall. Helmet standards do not address these issues--it's up to you to make these choices.

REPLACING YOUR HELMET

You should always replace your helmet after any significant crash. Damaged helmets should be thrown away or returned to the manufacturer. Many helmet companies offer "Replacement Policies" and will replace a crashed helmet free, or at reduced cost.

THE LIFESPAN OF A BIKE HELMET

Common wisdom is that a styrofoam bicycle helmet should be replaced every three to five years, depending on how hard it is used, exposure to the elements –

especially sun – and original manufacture date. A sticker inside your helmet should tell you when it was "born."

HELMET RESOURCES

Helmets can usually be found at larger discount stores starting at around \$15. If you want a higher quality helmet, there are now discount purchase programs available to school, community, and faith-based groups, to help provide access to people who otherwise might have to spend the cost of a helmet on something more urgent, like rent or groceries.

HELMET SAFETY STANDARDS

CPSC and Snell are the two helmet certifications to look for when buying a new helmet. The older ANSI and ASTM standards may also be found in older batches of helmets still in retail stock. Look for CPSC and/or Snell certification stickers inside the helmet.



SF Bicycle Coalition volunteers distribute free helmets to youth, and do bike tune-ups at a community event in the Bayview.

Avoiding Collisions and Injuries

Wear your helmet! Helmets will never prevent collisions, but they do a great job of preventing brain injuries when worn properly. For more information, see the section on HELMETS in this Guide.

EMERGENCY BICYCLE HANDLING SKILLS

Sometimes you'll do everything right and still end up in trouble. It is a good idea to learn a few physical skills that will allow you to take evasive action when you find yourself in a sticky situation. These and other skills are part of the "Road 1" class offered free by the San Francisco Bicycle Coalition in collaboration with the SFMTA Bicycle Program and the San Francisco County Transportation Authority (See BICYCLE EDUCATION section of this Guide.) This class, in conjunction with the in-class "Street Skills" session, provides cyclists with training in urban riding skills that will reduce the risks of collision and injury. Both classes are based on



Instructor teaching safety skills during "Road 1" class.

the national curriculum of the League of American Bicyclists (LAB) and are taught by certified LAB Cycling Instructors (LCIs). For more information on these classes, or on becoming an LCI, please call 431-BIKE or visit www.sfbike.org/edu.

The following skills can help you avoid crashes and collisions. Each skill takes practice to master, but is worth the time and effort. Practice these maneuvers in a safe, controlled place – not on the street in traffic!



Shoulder check near the Civic Center.



Instructor teaches the shoulder check at "Road 1" class.

SHOULDER CHECK: This is simply looking behind you over your left shoulder to see what is coming behind you. Why look over your left shoulder? It's the one that is on the side of traffic, and when you look over it, you'll see what traffic is coming up behind you. Practice looking back over your left shoulder without swerving. You need to be able to do this shoulder check while riding a steady straight line, so that you don't swerve into traffic or into parked cars! An easy way to practice this is to ride straight away from a friend and have them hold up some fingers. When you look back yell out how many fingers they are holding up. Repeat this drill until you can ride straight while looking back, and are comfortable doing it.



As the rider brakes for a "Quick Stop" she shifts her weight back on the seat and lower, to improve traction on the asphalt.

QUICK STOP: This skill involves stopping as fast as you can, without skidding, losing control, or going over the handlebars. As you begin to brake evenly with both brakes, you will slide your weight back on your

seat, giving the rear tire more traction. This will help you stop faster and under better control. In a typical stopping situation, 80% of your weight is on your front wheel. At high speeds this can mean that you lose control, that your rear tire skids, or that you fly over your handlebars.



"Road 1" students dodge a sponge while learning the "Rock Dodge".

ROCK DODGE: The Rock Dodge is a simple and useful skill for urban riding. It allows you to quickly and easily avoid rocks, glass, bottle crowns, small potholes, and other things you don't want to ride over or through. To practice this skill, while riding straight at speed, you will first "twitch" your handlebars slightly one direction, and then "twitch" them back in the opposite direction. This steers the bike out from underneath you and instantly creates a slight lean in your bike, while allowing your body to continue in its straight path of travel. The wheels and tires will avoid the rock and you'll still be happily on your way. You may also want to put your weight on your pedals and lift your weight slightly from your seat. If you hit the rock with your

weight on your seat, you are more likely to get a flat tire. If you shift your weight to the pedals, this type of flat tire can usually be avoided.



Students practice instant turns during “Road 1” class.

INSTANT TURN: This skill is useful in avoiding a collision when a car overtakes you and makes a right turn in front of you. If you do not have time to stop, you’ll need an escape route and the best thing to do is to follow the car around the corner. This requires high speed cornering skills, that you can gradually learn from this drill. The other time this is most useful in city traffic is when you have an oncoming vehicle make a left turn in front of you.

In order to practice this skill you need an asphalt surface (playground, tennis or basketball court, empty parking lot, etc.) Start slowly and pick up speed as you repeat the drill and get more comfortable with this skill. As in the Rock Dodge above, while riding straight at speed, you will first “twitch” your handlebars slightly, but in the opposite direction of the way you want to turn. This steers the bike out from underneath your body and instantly creates a lean in the direction you wish to turn and prepares you to turn much sharper without losing control. After the “twitch” of the handlebars you will then turn your handlebars the other direction and turn hard into your INSTANT TURN.

NOTE: This skill is awkward-feeling and it will take some time to develop a comfort level while doing the Instant Turn. At first, your body will fight to do the opposite of what you ask it during this drill. For this reason you should start slowly and build the skill as you get more comfortable.

Grates, Plates, Trenches and Potholes



Utility covers are ground smooth over the years and become more slippery.

The streets of San Francisco are under nearly-constant repair. The resultant steel plates, open trenches, and asphalt patch-work add obstacles to the existing tapestry of metal utility covers, sewer drain grates, and BART/Muni ventilation grates. Potholes and broken pavement can also require your full attention. Metal utility covers can be also be slippery and often make for a rough ride. All of these potential obstacles require your attention and care in navigation. **Potholes and broken pavement should be reported to DPW Street Repair at 311 or online at www.sfgov.org/311.**



This drain grate is aligned to prevent trapping bicycle wheels.

DRAINAGE GRATES aligned parallel to your path of travel should be avoided, lest your wheel fall in. In the 1990's Peter Tannen, former Bicycle Program Manager, rode every street within the City limits and had every misaligned drain grate replaced or retrofitted. For this Herculean task Tannen was recognized by the California Bicycle Safety Network, and his efforts ensure that one less common obstacle plagues San Francisco bicyclists.



A misaligned drain grate can trap a bicycle wheel.

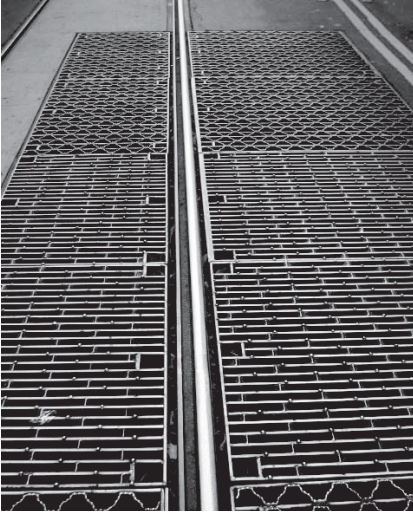

BART grates and Muni tracks present issues for bicyclists.

It requires skill and balance to safely ride across the **BART/MUNI VENTILATION GRATES**, and it is advisable to avoid them even in dry conditions. When wet they are especially slippery. After the construction of the Muni Metro and BART underground

systems, the local bicycle messenger community dubbed these grates “The Cheese Graters” after witnessing cyclists crash on them. You will find these large grates on Market and Mission Streets. Be prepared.

The **HEAVY STEEL CONSTRUCTION PLATES** used to cover trenches and other roadway construction are required by City Code to have non-skid surfaces. Unfortunately, sometimes the non-skid coating wears off, or old smooth plates are used. Without a non-skid coating these plates are slippery and can be hard to negotiate. All street trenching work must be patched and/or ramped every day – no abrupt edges of $\frac{3}{4}$ inch or more may be left overnight. **Report any smooth plating or open trenches you encounter to the DPW at 311 or online at www.sfgov.org/311.**



This construction plate lacks required non-skid coating.

What to do if you get in a collision

If you are involved in a bicycle crash, always assume you are injured and **DON'T REFUSE MEDICAL ATTENTION**, even if you feel that you may not need it. You may be in shock, injuries may not be apparent immediately, and professional medical documentation is critical in any insurance claims, not to mention for your health and well-being.

CALL 911 AND REPORT THE COLLISION IMMEDIATELY, or 553-8090 for EMERGENCY DISPATCH FROM A MOBILE PHONE.

ALWAYS MAKE A POLICE REPORT. If you are injured, it is required that the Police come to the scene and make a complete collision report. **IF YOU DO NOT GET A POLICE REPORT ON THE SCENE**, obtain the other driver's license number, insurance information, vehicle license plate number and description of both the car and driver. If this isn't all possible, write down or remember the license plate number. In property damage-only collisions, the police are not required to come to the scene to complete a report. In this case, you should go to the local police station and file a "counter report". This is critical in the event of later insurance claims or legal action.

DON'T DISCUSS FAULT IMMEDIATELY AFTER A COLLISION. You may want to reassure a shocked driver that things will be okay, but don't say anything that limits

or admits fault in the collision. Make sure to write down what you think happened as soon as possible, and in as much detail as you can remember. If you can, draw a diagram of how the collision happened. Always carry ID, medical insurance information, and emergency contact information, especially if you're riding alone.

DOCUMENT YOUR INJURIES AND PROPERTY DAMAGE with photos or videotape, and save all receipts and repair estimates. Save your bike even if it has been totaled. Contact your insurance company if you have coverage for your bicycle. You may also want to contact an attorney.

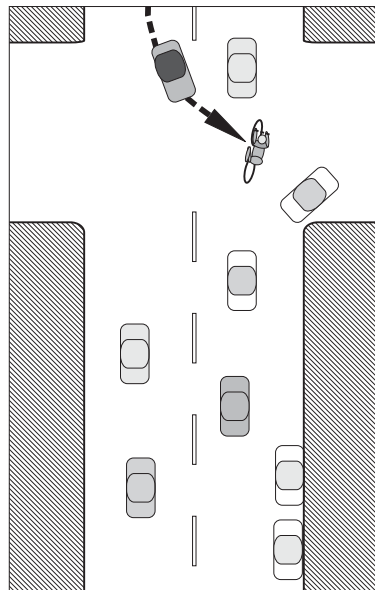

Failure to Yield when Turning Left

The CoExist Campaign

THE COEXIST CAMPAIGN is an ongoing effort by the MTA Bicycle Program and the San Francisco Bicycle Coalition. Initiated in 2001, the campaign combines outdoor media messages, grassroots level promotional incentives, and even engineering implementations to foster cooperation and peaceful use of shared lanes on San Francisco streets.

A primary objective of the CoExist Campaign is to ensure that bicyclists will not ride in the "door zone," where they are

at risk of collision with the open doors of parked cars. Critical to this effort is alerting motorists that bicyclists have the right to share the traffic lane, and that motorists should pass bicycles safely, with caution and respect. For more information on CoExist, or to get CoExist stickers, go to www.sfmta.com/bikes or www.sfbike.org.



CoExist stickers for bumpers and bikes.

These light-hearted posters sought to engage both bicyclist and motorist, promoting safe lane sharing.



MAKING A SENSITIVE PASS CAN PAY OFF DEARLY



Bicycle Safety Education



A "Road 1" student completes the written test.

FREE Nationally Certified Classes for Bicyclists!

In a collaboration between the San Francisco Bicycle Coalition, the SFMTA Bicycle Program, and the San Francisco Transportation Authority, the city offers adult bicycle education classes. In-class "Street Skills" and on-road "Road 1" classes are offered at regular intervals throughout the year. These classes are a recognized national curriculum from the League of American Bicyclists Bike Ed

Program, and are taught by trained and certified League Cycling Instructors (LCIs). For more information on the League of American Bicyclists, visit www.bikeleague.org or call (202)-822-1333. The two part series is designed to teach new and novice cyclists the skills and awareness to bicycle safely and confidently in urban environments. For more information, or to sign up for classes, visit www.sfbike.org/edu or call 431-BIKE.



New Instructors prepare for Road 1 class, with lead instructor Bert Hill (left).



Susan Silber teaches new riders at World Environment Day, 2005 .



Kids learn safety skills and get their bikes tuned up at Bayview Fit-n-Fun Fair.

The Waller Street Bicycle Learning Area

The City also has a Bicycle Learning Area on a closed block of Waller Street west of Stanyan Street. The Learning Area is designed for use by individuals, organized groups, and the City-sponsored bicycle safety classes noted above. You can practice safety skills there without having to worry about traffic or pedestrians. For more information and an instructional brochure, call 585-BIKE or go to www.sfmta.com/bikes or visit any bike shop on Stanyan Street.

THE WALLER STREET BICYCLE LEARNING AREA is designed to be used both as a self-service practice and training area for adult bicyclists who wish to prepare themselves for the skills necessary to ride on city streets, and as a child bicycle safety instructional facility where parents and/or trained cycling instructors may teach children the “rules of the road” and bicycle safety lessons.



Bicycle Safety and Education Programs

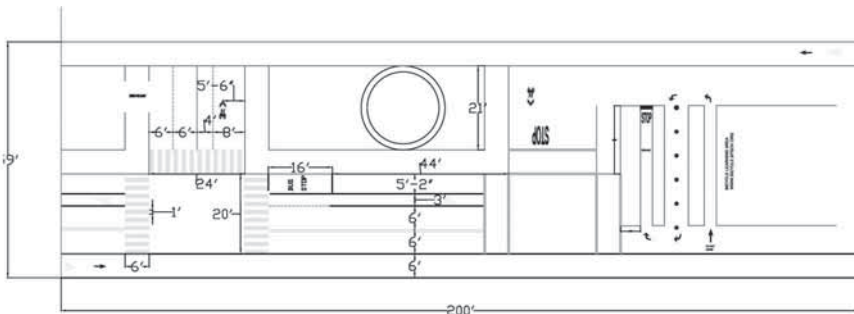

The layout of the Bicycle Learning Area includes skills stations and mini streets.

The Learning Area is organized around THREE BASIC BICYCLE SAFETY PRINCIPLES:

1. Bicyclists must be visible to others using our streets.
2. Bicyclists' behavior must be predictable.
3. Bicyclists must communicate with all other types of street users.

Defensive cycling is key to safe bicycling in urban areas. Be prepared for conflicts and practice behaviors and skills which minimize or avoid these conflicts.

The drill stations and mock streets within the Learning Area are designed to build both the physical skills necessary to ride on city streets, and the awareness of and correct bicyclist positioning on different types of streets and travel lanes.

Bicyclists should always be in control of their bicycle and responsible for their actions.

STATION 1: LOOK OVER YOUR LEFT SHOULDER

This drill is a fundamental of urban cycling. The rider must be able to look back over her/his left shoulder (which is closest to the path of motor-vehicles) and check for traffic approaching from behind. This must be done while maintaining a straight path of travel. The rider does not want to veer into moving traffic or into parked cars while making a shoulder check.

STATION 2: WEAVE / ROCK DODGE

Station 2 is designed to help the rider develop or assess the fine motor skills necessary to steer the bicycle in tricky situations. It can be used both to develop simple steering skills, and then later to develop emergency maneuvers, such as the "rock dodge," which can be used to avoid potholes or debris in the path of the bicycle.

The rider begins by riding around the marked spots on the ground in a series of "S" patterns. For the "rock dodge" the rider practices a more instantaneous "flick" of the handle bars that allows the bikes' tires to avoid the spot, while the rider's body maintains more of a straight path of travel. This second maneuver requires more comfort and skill on the bicycle and should only be added after a rider can easily navigate the Station and has increased the speed with which they can do so.

STATION 3: BRAKING AND STOPPING

Controlled braking and stopping are very important to safe bicycling. This Station is designed to teach the rider how to brake in a controlled manner, and stop at a designated spot without skidding, losing balance, or otherwise losing control of the bicycle.

The rider pedals from the start line to the line that says "BRAKE." At this line, the rider begins to apply the brakes. Hand

brakes should both be applied evenly and equally. Foot, or “coaster,” brakes should be applied evenly while the pedals are in the “3 and 9 o’clock” position with both pedal cranks parallel to the ground. This gives the rider the most control of the brakes and allows for even downward pressure on the pedal used for braking.

Note: Riders should practice braking without skidding! A skid does not give the rider control...and needlessly wears out tires.

STATION 4: CHAOS CIRCLE

The circle is designed to teach children the need for basic traffic rules, and to further develop handling skills. Groups of more than 6 riders should be sent to ride inside the circle with a single rule: “Stay in the circle.” Riders will experience conflicts, near collisions, and frustration. After letting them ride for only a moment or two, an instructor should stop the group and ask what was happening and why. The riders will already see the need for rules and some kind of order. This is an opening to explain why we have traffic laws and “rules of the road.” Beginning with the simplest of

rules, using the correct side of the street. Ask them to imagine the mayhem if all street users drove, rode, and walked in the way they had just been doing in the circle, with no other rules.

Children can then be instructed to ride within the circle, with some rules: ride clockwise; ride two abreast; etc.

Riders can also practice riding in a controlled space by doing a “lap” around the inner circle in each direction without touching the inner or outer circle.

STATION 5: MOCK STREETS

The miniature streets are designed to provide a training ground for practicing riding on the types of streets riders will encounter while riding in the city. It is suggested that novice bicyclists choose streets with slower more calm traffic until they develop the skills and experience to negotiate streets with heavier traffic and multi-lane streets with more complex situations and traffic patterns. When in doubt, take the safer or less-traveled route.

Bike Parts and Terms

Know your bike. The illustration below names the parts of typical bikes.

Parts of the Bike

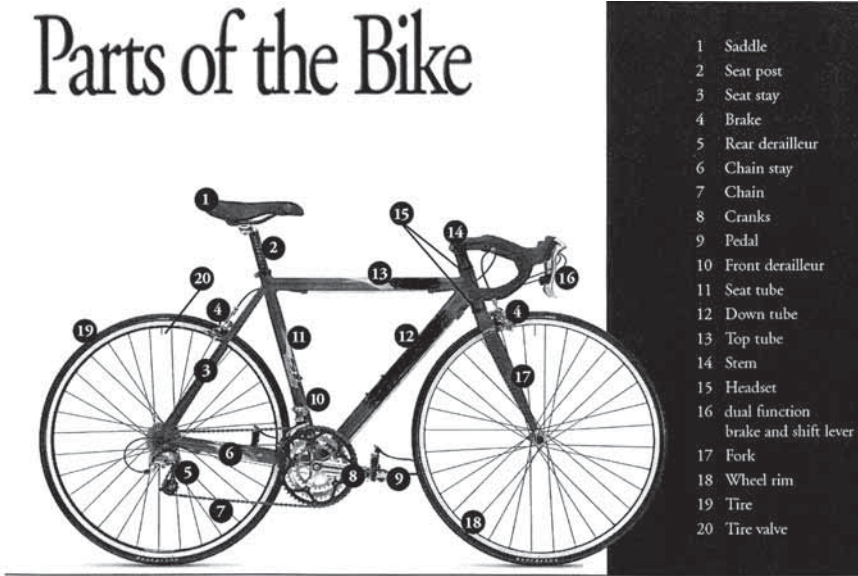

Bicycle Sizing and Fit

Your bike should fit your body. Seat height and reach to the handlebars are essential, and more subtle sizing issues help to make your bike a close extension of your body. Correct bike fit allows you to completely control your bike.

SEAT HEIGHT

Your seat should be at the height where your reach to the pedal in the bottom position almost fully extends your leg straight, but not quite. If your seat is too high, it may cause you to rock uncomfortably back and forth or overextend your legs, which could cause injury. Correct seat height does not allow for the rider to sit comfortably on the seat and touch the ground with both feet. You should only be able to reach the ground with one foot, and will probably have to stretch to do so. Novice riders and children may want the seat height a bit lower than normal in order to feel more comfortable getting on and off the bike. As the cyclist gains more experience on the bike, the seat height should be raised to its full correct height.

HANDLEBAR REACH

Handlebar reach is more an issue of comfort, use, and even medical history, such as back injury. City riding generally calls for a more upright riding position, meaning a shorter reach from the seat to the handlebars. An upright position allows the rider to see better in traffic and be seen better by drivers and pedestrians. Being visible to others and seeing your urban environment are both key to avoiding common collisions. Most sport riders, whether road riders or mountain bikers, choose a position leaning more forward. This position gets the rider lower, reduces wind resistance and distributes the rider's weight more evenly, but can limit visibility. One general rule is that you never want to have your handlebars so far forward that you have to lock your elbows to reach the handlebars, as it will reduce your ability to react and steer fluidly and quickly.

PROFESSIONAL BICYCLE FITTING

All quality bike shops offer a professional bicycle fitting.

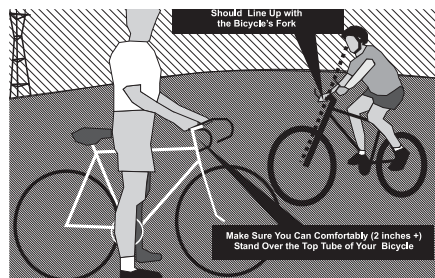

Correct Bicycle Fit

Gearing and Shifting

The gears on a bike allow you to ride all kinds of terrain: flats, up hills and down hills. Learning to use the gears may come easily to some riders, or may be more of a challenge. With San Francisco's hills, it is a good idea to learn to use your gears, or you'll likely be walking up some of our steeper streets.

BICYCLE GEARS are changed in two groups: front "chain rings," located on the pedal cranks (see picture below), which are changed by using the shifter lever on the left handlebar; and rear gear "cogs," located on the back wheel (also pictured below), which are changed by using the shift lever on the right handlebar.

Note: many bicycles are now equipped with indicators on the shifters that show which gear you are in. (ie. Gears 1-8 on the right shifter and Chainrings 1-3 on the left shifter. In this case the lower the number, the lower the gear.)

When the chain is on each of the front chain rings, there is a corresponding group of gears (5-11 gears) on the back wheel that you can use. The small chain ring, which is closest to the inside, and nearest the bike frame, allows you to use the lowest set of gears. These lowest gears are used for climbing steep hills. The middle and outer chain rings give you a middle range of gears and a high range of gears. The middle range of gears are the most commonly used. The high gear range is usually used for going fast on flat roads or going downhill.

If you sit on your bike and look down at the chain and gears they will look something like the pictures below. On both the front chain rings and rear gear cogs, when the chain is on the left side of the range of gears, you are in a lower gear. Conversely, when the chain is on the right side of the range of gears, you are in a higher gear.

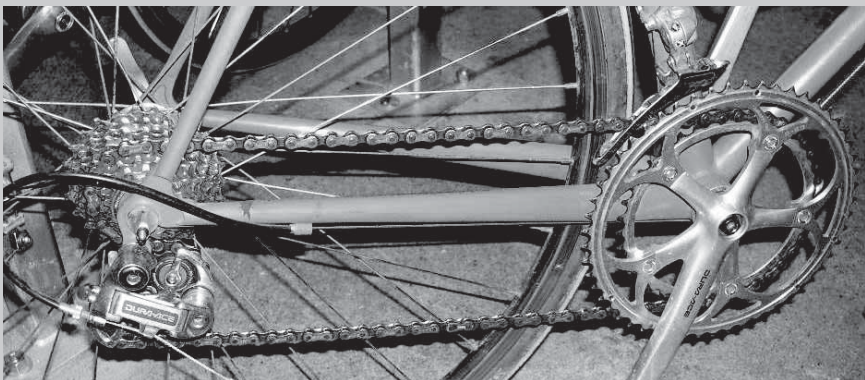

Side view of a bicycle drive-train: rear gear cogs; rear derailleur, chain, front derailleur, front chain rings and pedal cranks.

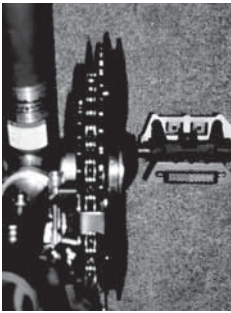

Front chain rings (3)

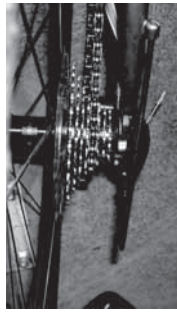
Rear gear cogs
(8 speed)

These two types of mountain bike shifters both show the rider what gear the bike is in.

HOW MANY GEARS DO I HAVE?

If you have 9 or 10 gear cogs on the rear wheel, and 3 front chain rings, you have 27 gears (9 gears x 3 chain rings) or 30 gears (10 gears x 3 chain rings). This wide range of gears allows the rider to ride at a more consistent level of effort when riding uphill, downhill or on the flats. Learning to use your gears effectively will allow you to ride more smoothly and comfortably in all situations. Practice

PEDALING CADENCE

(pedal revolutions per minute)

"Cadence" is how fast you are pedaling. Combined with the gear you are in, cadence dictates how fast your bike goes. Typically, a pedaling cadence of 75-90 revolutions per minute is the most efficient and has the least impact on your knees. Assuming that you pedal consistently at 75 rpms, and you are in a "low" gear that turns the rear wheel a lower number times per pedal revolution, your bike will go slower. At the same pedal RPMs, when you are in a "high" gear, your bike will go faster.

SHIFTING GEARS

Shifting gears on your bike is done by moving the shift levers to pull (or release) metal cables, that in turn move the front and rear derailleurs. The derailleurs in turn move the chain from one chain ring (front gears) or gear cog (rear gears on the back wheel) to another.

YOU CAN ONLY SHIFT GEARS WHEN YOU ARE PEDALING!

The chain must be moving in order for it to move from one gear to another, unless you have an internal hub gear system. If you shift when the pedals are not turning, the result will be a noisy and abrupt change of gears when you start pedaling again, and you may even cause the chain to fall off of the chain ring or rear gear cog.

ANTICIPATE WHEN YOU WILL NEED TO SHIFT. If you are approaching a hill and will need a lower gear to climb the hill, don't wait until you are struggling to pedal up the hill to change gears. Shift before your pedaling cadence starts to slow down, and you will make a smoother transition into the hill. Similarly, if you are going down hill, you may want to shift before you build up too much speed, or when you begin to pedal your pedals will spin freely and not help to push you down the hill. Finally, shift to a lower gear as you approach stop signs and red signal lights. You'll need a lower gear to start from a stop, and shifting while trying to begin riding across a busy intersection may be troublesome, directing your attention away from the traffic and down to your gears. Also, starting from a stop in high gear is slow and hard, and puts undue strain on your knees. Prepare for stop signs and signals by shifting down as you slow to a stop – and remember to keep pedaling while you shift, or you'll start out on the green light by having your chain jump violently from the old gear to the new one.

Brochures and Publications



THE SAN FRANCISCO BIKE MAP AND WALKING GUIDE is an excellent resource for planning bicycle trips throughout the City. The map shows all the bicycle routes within the city, indicating the type of bicycle facility on each street or path. The map also shows street grades, so that the cyclist may plan the flattest routes through the city's hilly terrain. The back side of the map also contains important safety information and handy transit linkages for bicycles (also see the TRANSIT section of this guide). The map may be purchased at local bike shops, book stores, and select grocery stores. You may view a .pdf version of the map at www.sfmata.com/bikes.

FROM A TO Z BY BIKE, is a safe cycling guide for kids and adults, published by AMC Media, PMB 729, 250 "H" Street, Blaine, WA 98230. To obtain free copies of this booklet call 311 or email bicycle@sfmata.com.

SAFE BICYCLING IN SAN FRANCISCO

is out of print, but this early safety guide is still available for viewing at www.sfmata.com/bikes.

FIND THE TWELVE HAZARDS

This single sheet lets children identify common obstacles to safe bicycling. For free copies with answers on the back, call 311 or email.

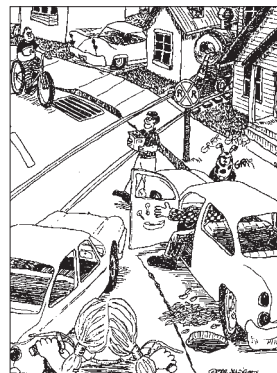



Important Telephone Numbers and Internet Links

Bicycle Information Hotline

Bicycle Safety Information

Bicycle Rack Installation

311

www.sfmnta.com/bikes

San Francisco Bicycle Coalition

431-BIKE (2453)

Bike Buddy Commute Program

(Bicycle commute assistance)

www.sfbike.org

SF Bicycle Advisory Committee

311

www.sfmnta.com/bikes

SF Police Department

EMERGENCY: 911

Non-emergency (24 hr): 553-0123

SFMTA Parking Enforcement

311

Abandoned bikes

311

To Report Debris in Bike Lanes

311

DPW Street Construction Center

311

Potholes: DPW Street Repair

311

Bay Area Regional Bicycle Information

511 or www.511.org

-also traffic and Transit info

California Bicycle Coalition

(916) 446-7558

Caltrans Bicycle Program

(916) 653-2750

League of American Bicyclists

(202) 822-1333

www.bikeleague.org

National Bike Registry

www.nationalbikeregistry.com

Muni General Information

311

SFMTA Reception Front Desk

701-4500

